

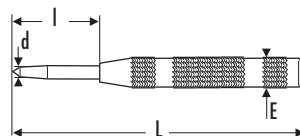

PUNKTAKI AUTOMATYCZNE

- Końcówka o twardości 56-61.
- Siła wyzwolenia sprężyny E150503 : od 6 do 12,5 kg - E150504 : od 12,2 do 18,5 kg.
- Korpus z brązu.

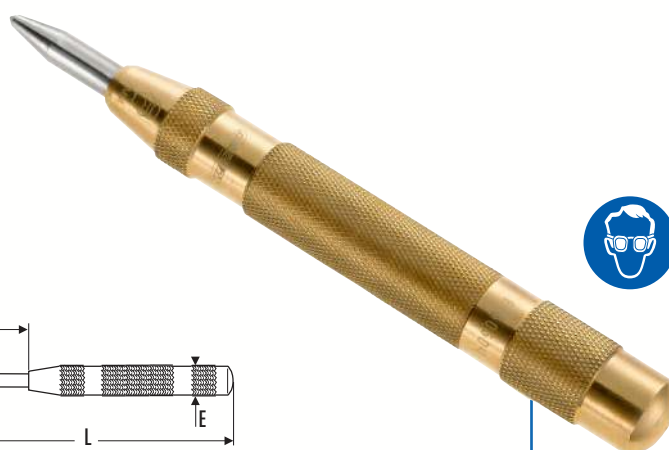

	d mm"	E mm	L mm	l mm	Waga g	☒	EAN
E150503	4	14	130	27	72	1	3258951505038
E150504	7	17	151	26.7	133	1	3258951505045

PRZECINAK EKSTRA-PŁASKI 26 MM

- DIN 7255
- Hartowane na 54-58 HRC.

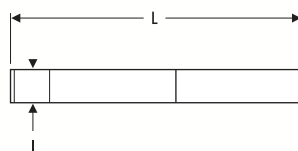
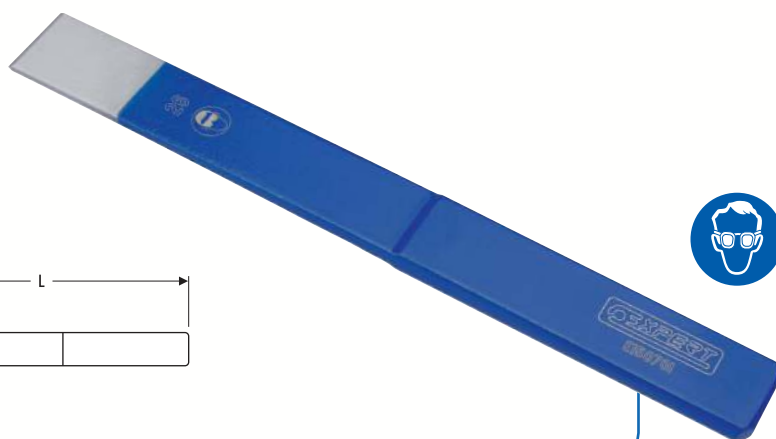

	L mm	l mm	Waga g	☒	EAN
E150701	235	26	250	1	3258951507018

PRZECINAKI O PROFILU STAŁYM

- DIN 7255
- Hartowane na 54-58 HRC.

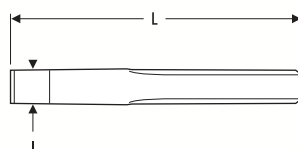

	L mm	l mm	Waga g	☒	EAN
E150702	150	21	195	1	3258951507025
E150703	200	24	350	1	3258951507032
E150704	250	27	510	1	3258951507049

